

Model: ENERGY

ET107V

SPECIFICATIONS:

Year of Intro	2000
Thrust	107 LBS
Volts	36VDC
Amp Draw	0 to 48 amps
Mount	09 Transom
Speeds	Variable with Fwd/Rev

TO ORDER PARTS:

MotorGuide Consumer Relations
 Phone 918-831-6989
 Fax 800-982-8093

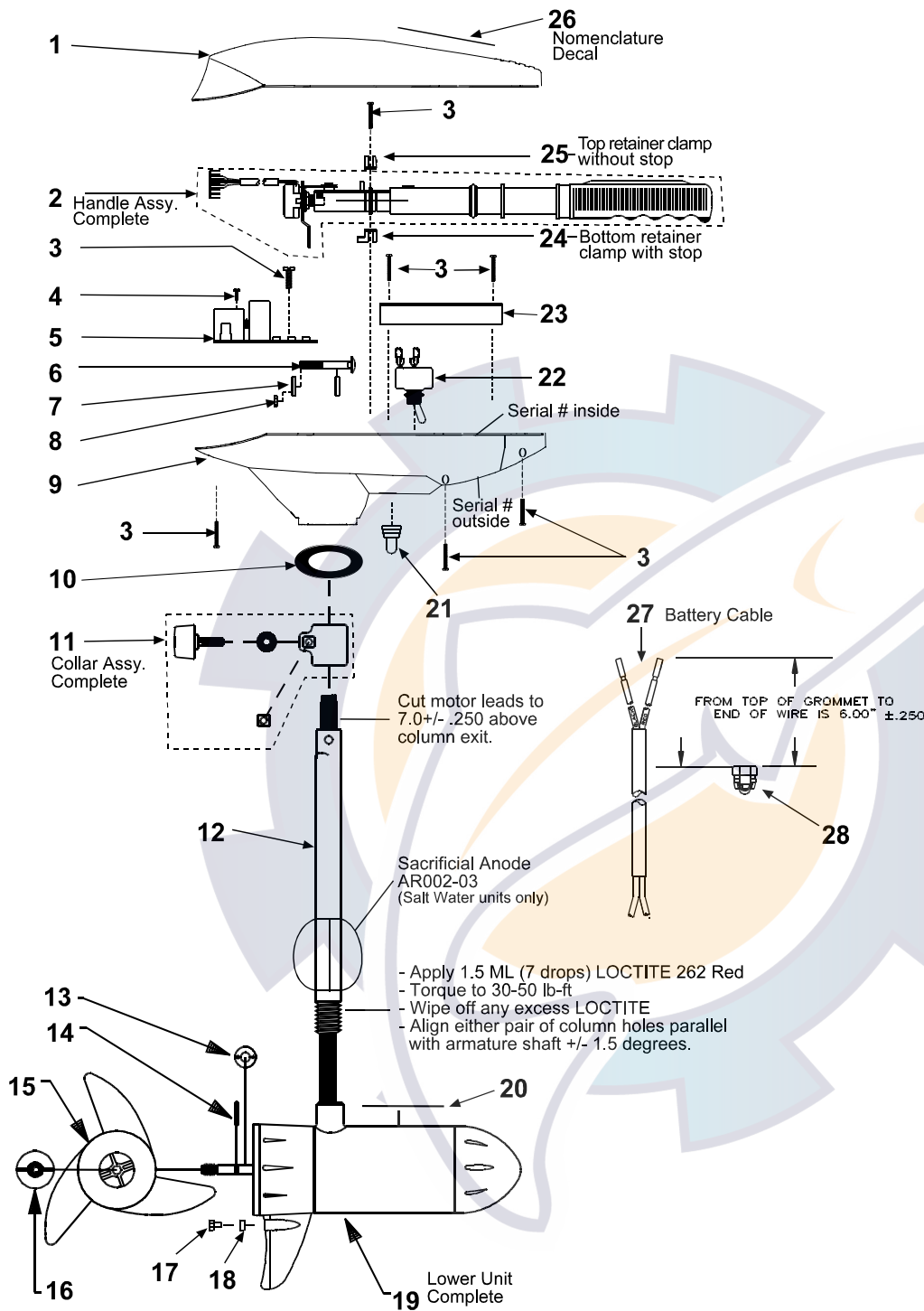

KEY	DESCRIPTION	PART #	KEY	DESCRIPTION	PART #	KEY	DESCRIPTION	PART #
1	TOP HOUSING COVER BLACK	ET053-17	12	COLUMN 36"	TT049-05	20	LOWER UNIT DECAL	ET060-08
2	HANDLE ASY	ET372-06	13	COLUMN 42"	TT049-06	21	SWITCH BOOT	FP177-01
3	#8 X 5/8 SCREW	AT141-01	14	COLUMN 50"	FR049-13	22	TOGGLE SWITCH	FP153-07
4	#4 SELF TAPPING SCREW	XT141-02	15	PROP DRIVE PIN	AR175-01	23	CABLE PLATE	AT155-06
5	CIRCUIT BOARD FOR/REV	AT157-03	16	PROP/3 BLADE	BR102-01	24	BOTTOM RETAINER CLAMP	AR036-02
6	BOLT	TT134-02	17	PROP/2 BLADE	AF124-12	25	UPPER RETAINER CLAMP	AR036-04
7	CURVED WASHER	TT171-08	18	PROP NUT	AF124-07	26	NOMENCLATURE DECAL	AT056-22
8	NYLON LOCK NUT	XT098-02	19	ANODE BOLT (Saltwater models only)	AR099-01	27	BATTERY CABLE	XT328-06
9	T/H BASE BLACK	AT004-11		ANODE (Saltwater models only)	DK133-01	28	GROMMET	GR019-01
10	COLUMN SEAL	AT079-01		MOTOR	AR002-02			
11	DEPTH ADJUSTMENT COLLAR	AR158-01			XF397-01			

LOWER UNIT BREAKDOWN

Model: **ENERGY**
ET107V

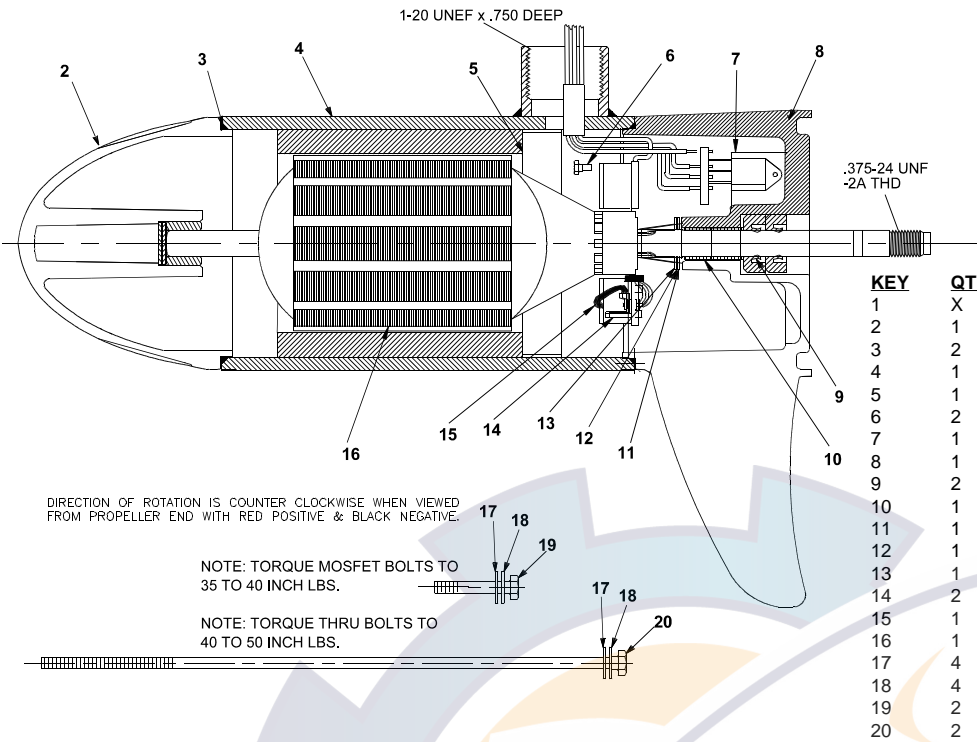

KEY	QTY	DESCRIPTION	PART NO.
1	X	MOTOR	XF397-01
2	1	NOSE CAP	XF3212-01
3	2	O RING SEAL	MR217-01
4	1	HOUSING ASY	XF3210-01
5	1	RETAINER	JF233-01
6	2	BRUSH CARD SCREW	MR228-01
7	1	DURA AMP MODULE	JF096-09
8	1	COMM CAP	XF3205-01
9	2	SHAFT SEAL	MR223-01
10	1	BEARING	MR206-01
11	1	NYLATRON WASHER	MR226-01
12	1	WASHER	MR227-01
13	1	E RING	MR219-02
14	2	BRUSH SPRINGS	XF214-01
15	1	BRUSH ASY LESS SPRING	XF3201-01
16	1	ARMATURE	XF3207-01
17	4	STATIC SEAL	MR222-01
18	4	THRU BOLT WASHER	MR216-01
19	2	DURA AMP SCREW	MR229-04
20	2	THRU BOLT	MR218-18

WIRING

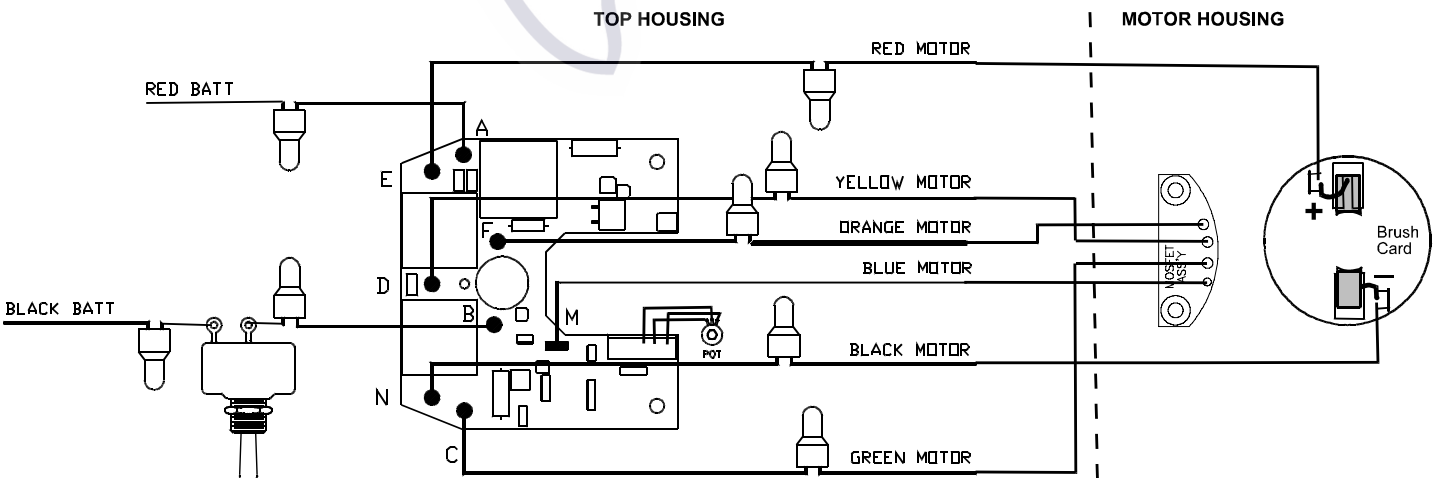
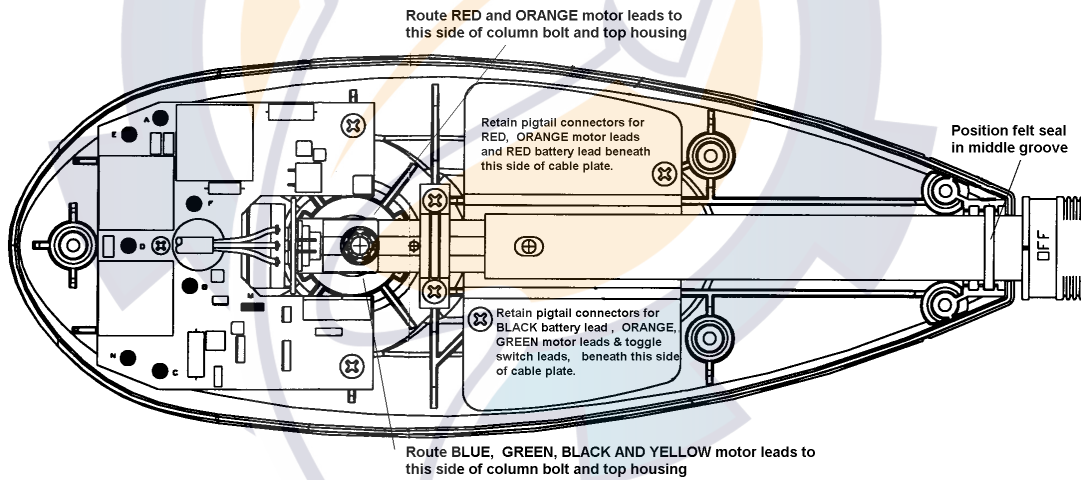

SUBJECT TO DAMAGE BY STATIC ELECTRICITY
ASSEMBLE AT STATIC FREE WORK STATION!